

1

2

3

4

5

6

7

A

B

C

D

E

A

B

C

D

E

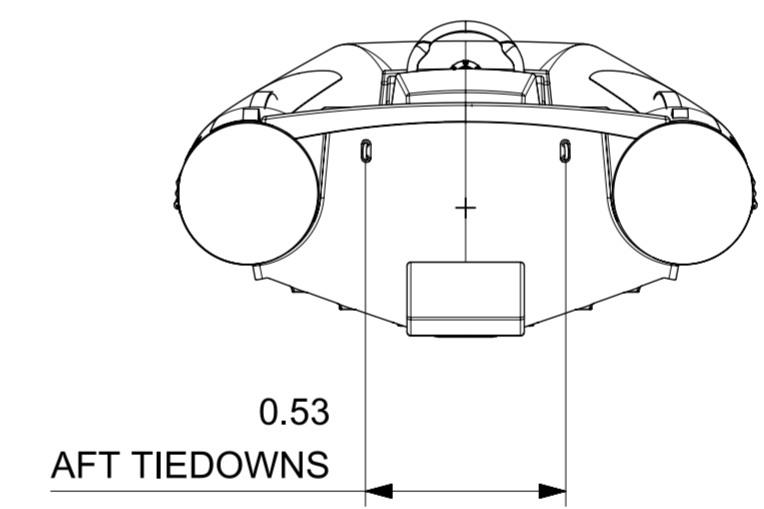
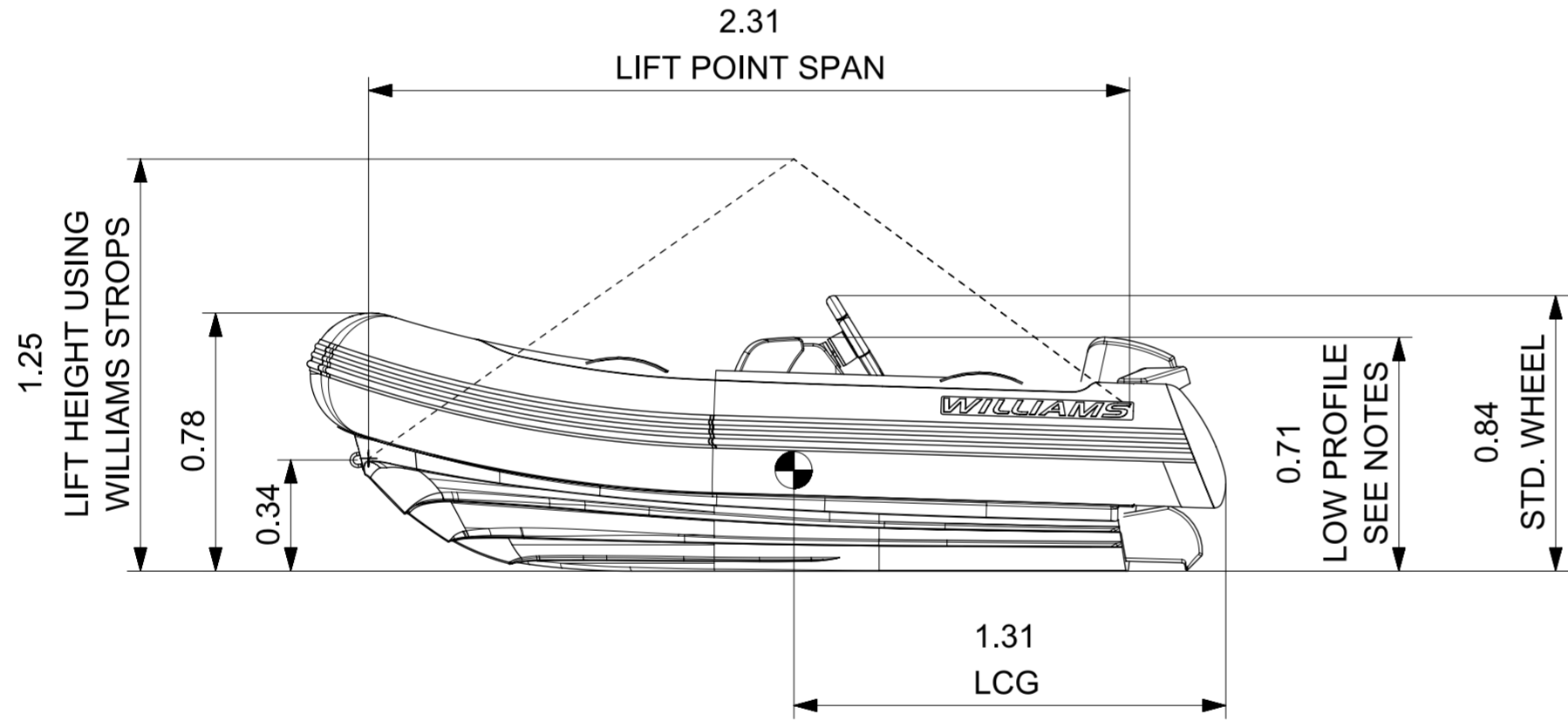
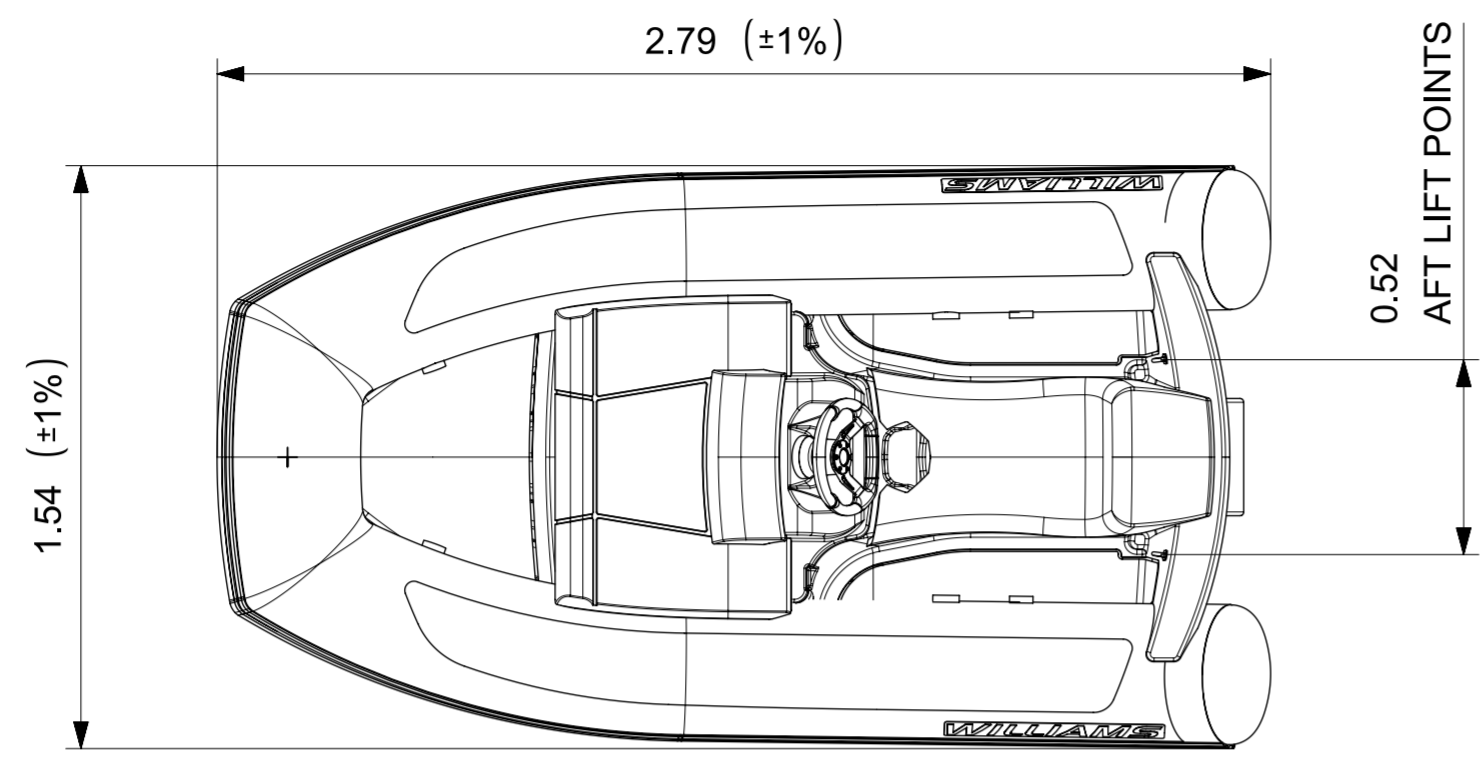

LENGTH O.A.	2.79m (±1%)
BEAM O.A.	1.54m (±1%)
DRAFT (FULLY LOADED)	TBC
ENGINE	ROTAX 900 ACE
POWER	45hp / 34kw
DRY WEIGHT	200kg
SEATING CAPACITY	4
FUEL	PETROL
FUEL CAPACITY	28 L
MAX. SPEED	35 mph / 56 kph
No. TUBE COMPARTMENTS	4
CE DESIGN CATEGORY	C

NOTES:

1. LENGTH / BEAM TOLERANCE DUE TO VARIATION IN TUBE PRESSURE.
2. AVERAGE DRY WEIGHT STATED; ACTUAL WEIGHT DEPENDENT ON OPTIONS FITTED.
3. LOW PROFILE SPEC:
 - DEFLATE TUBES
 - QUICK RELEASE STEERING WHEEL (OPTION).
4. CHOCK DRAWING: TBC
CHOCK PROFILES: TBC

PRELIMINARY COPY:
ALL FIGURES AND DIMENSIONS STATED SUBJECT TO CHANGE;
IF IN DOUBT, PLEASE CONTACT WILLIAMS JET TENDERS.

REV.	DATE	DETAILS	DRAWN	APPVD	GENERAL TOL. 0 +0.50 0.0 +0.25 0.00 +0.10 0' +0.50'	INSPECTION LEVEL: N/A	MATERIAL & FINISH	TITLE
								MINIJET 280 (2016MY)
					NOT FOR PUBLICATION - THIS DRAWING IS THE PROPERTY OF WILLIAMS PERFORMANCE TENDERS LTD. AND IS ISSUED ON CONDITION THAT IT IS NOT COPIED, RE-PRINTED OR DISCLOSED EITHER WHOLLY OR IN PART TO ANY THIRD PARTY NOT AUTHORISED TO RECEIVE IT	REMOVE ALL BURRS & BREAK SHARP EDGES GENERAL SURFACE FINISH Ra 1.6UM DIMENSIONS IN MM UNLESS STATED DO NOT SCALE DRAWING	PART NO. WPT-000280MJ-2016MY-DATASHEET	A2
							SCALE 1:20	SHEET 1 OF 1

